

FM FIRE ALARM SYSTEM

FIRE ALARM COMPLEX(P.B.L)SERIES PRODUCTS

Fire Manual Station/Call Point (Indoor) ISO 9001, CE Approved

• **Description:**

This Fire Manual Station can quickly transmit a signal to the fire receiver terminals or the repeaters while the button under a transparent protective cover has been pushed at the first finding of a fire accident. (This signal is beyond the accumulated time limitation.) There is a light over the button. The light will light up as a signal has been exactly received by the receiver terminal. There is also a telephone jack for telephone communication with attendant at the fire receiver terminal.

• **Specifications:**

Model No.	CM-FP1(recess)	Material	PC-ABS
Rated Voltage	DC 24V	Weight	Approx 155g
Rated Current	75mA	Color	Red

• **Advantages:**

1. Auto-Return by pushing button, no need to disassemble the main body.
2. Response light available to identify the operation completed.
3. Reinforced transparent protective cover is reusable.
4. All plastics are fire-proof, light, convenient and stylish.
5. Outside cord distribution with terminators to ease on work.

• **Mounting:**

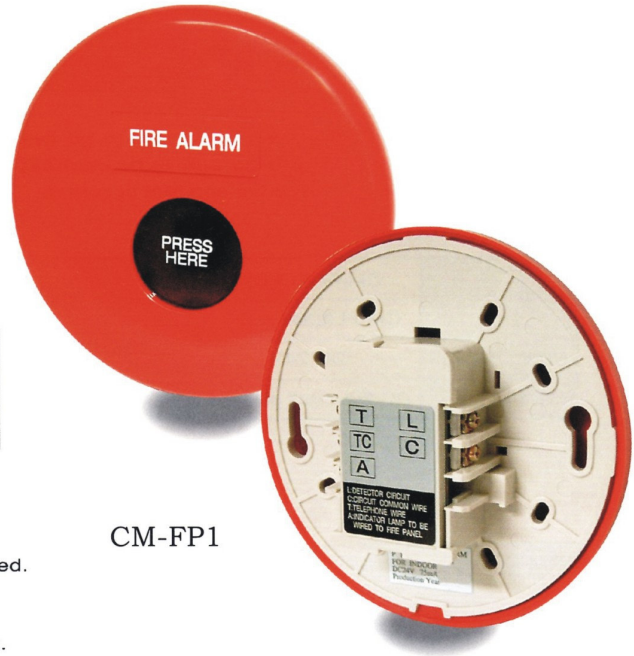
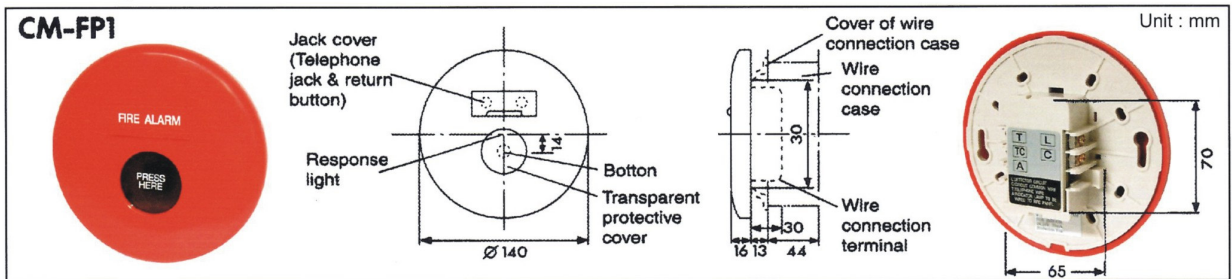

Fire Alarm Complex

- The Fire Alarm Complex is a steel box, in which there are indication lamp, alarm bell and fire manual station. In order to match the installation requirement, two types of surface mounting and recess mounting type are developed. They can also be installed uprightly or transversely. Push the button on fire manual station as soon as a fire accident found, the signal will be immediately transmitted to the fire receiver terminal. At the same time, the fire alarm bell will be ringing and the indication lamp will be also twinkling to give a warning.

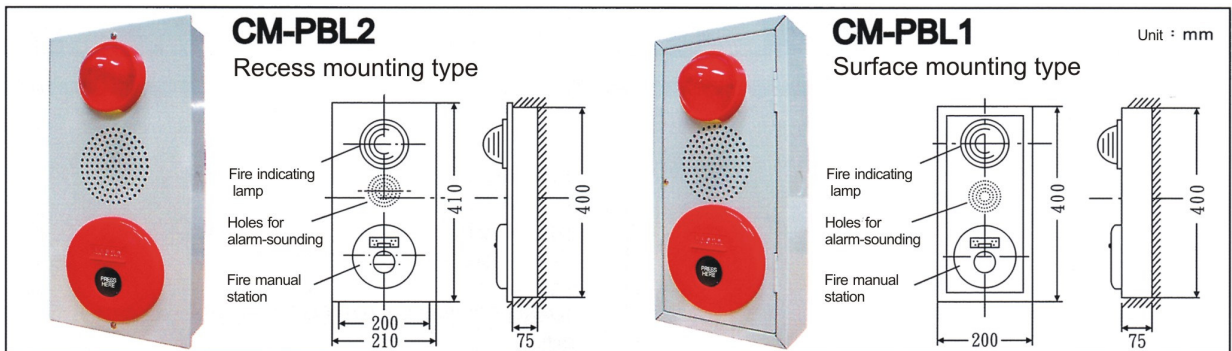

Fire Indicating Lamp (Indoor)

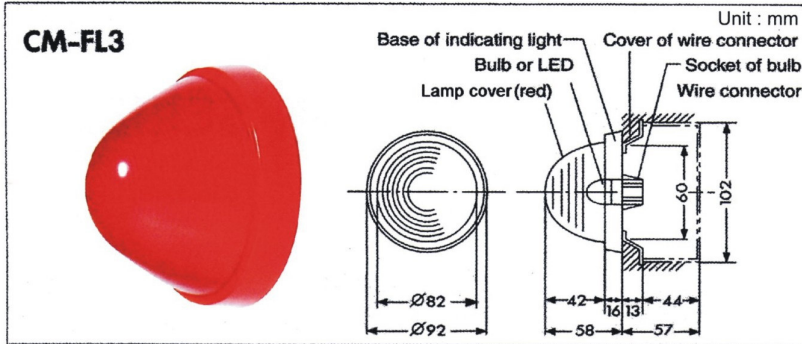

CM-FL20 Light Emitting Diode



Description:
Substitute for bulb in fire indicating lamp.

Specifications:
DC24V 20mA

Features:
• Light without heat.
• Service life up to 50000hrs.

- Description:**

The fire indicating lamp is an equipment to go twinkling, to show the position of a fire signal device and to be controlled by fire receiver terminal or a repeater while a fire accident occurred.

- Specifications:**

Model No.	CM-FL2(LED)	Rated Current	LED about 20mA
	CM-FL3(3W bulb)		3W bulb approx 100mA
Rated Voltage	DC 24V	Weight	Approx 55g
Material	PC fire-proof plastics	Color	Red

- Features:**

- The lamp cover and base are made of PC fire-proof plastics and are stylish outwards, durable with high temperature as well as able to bear forceful bump.
- The exceptional treatment on the interior surface of the lamp cover promotes the light quite even.

Fire Alarm Bell: 4 Inch (Indoor)

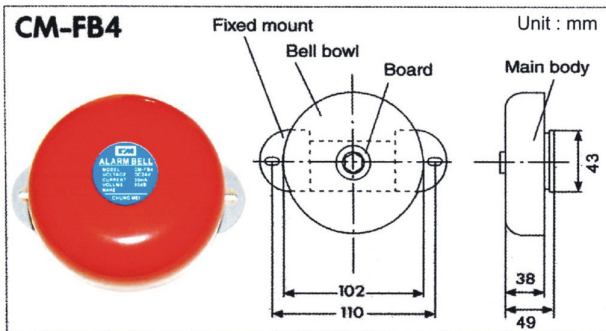

- Description:**

The fire alarm bell is an equipment controlled by the fire receiver terminal or the repeater and sounds a warning as a fire accident occurred.

- Specifications:**

Model No.	CM-FB4	CM-FB412	Power Source	Motor
Rated Voltage	DC 24V	DC 12V	Material	2.0mm Steel Sheet
Rated Current	30mA	60mA	Weight	About 333g
Volume	90dB		Color	Red

Fire Alarm Bell: 6 Inch (Indoor)

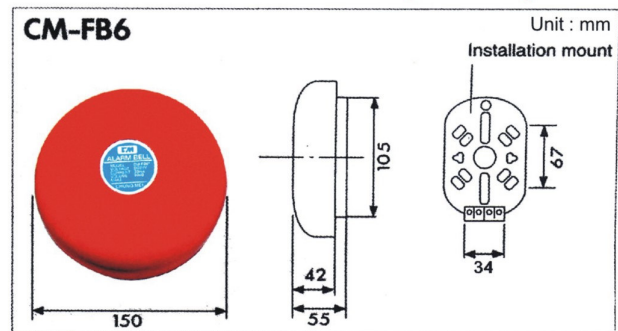

- Advantages:**

- The way of motor-driven is taken at the low consumption of current, to reduce the load for power output from receiver terminal.
- This design of exceptional structure is sturdy and durable. The bell even can ring to last 40 hours without decline of the performance and structure.

- Specifications:**

Model No.	CM-FB6	CM-FB612	Power Source	Motor
Rated Voltage	DC 24V	DC 12V	Material	3.0mm Alloy Alu
Rated Current	30mA	60mA	Weight	About 414g
Volume	90dB		Color	Red

DISTRIBUTOR: